

TECHNICAL DATA

Body material	Acetal resin
Thread	Metric and parallel
Seal	NBR rubber
Clamp	Stainless steel
Size	M5 ÷ G 1/2
Fluid	Air, vacuum
Working temperature	0 ÷ 60 °C
Operating pressure	0 - 10 bar
Negative pressure	-750 mmHg (-1 bar)
Max. pressure	15 bar
Recommended tubes materials	Polyamide and Polyurethane

STRAIGHT MALE

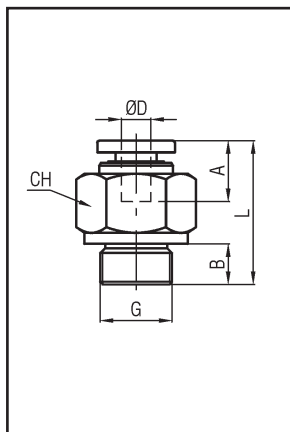

TYPE	L	A	B	ØD	G	CH	q.ty
RT-DM-4/M5	19,3	14	4	4	M5	10	10
RT-DM-6/M5	20,7	15	4	6	M5	12	10
RT-DM-4/01	19,5	14,6	5,5	4	G1/8	14	10
RT-DM-4/02	18,1	14,6	7,5	4	G1/4	17	10
RT-DM-6/01	20,7	15,2	5,5	6	M5	14	10
RT-DM-6/02	22,1	15,2	7,5	6	G1/4	17	10
RT-DM-8/01	25,1	16,2	5,5	8	G1/8	14	10
RT-DM-8/02	23,5	16,2	7,5	8	G1/4	17	10
RT-DM-8/03	21,1	16,2	8,5	8	G3/8	20	10
RT-DM-8/04	25,1	16,2	11	8	G1/2	24	10
RT-DM-10/02	29,3	18,7	7,5	10	G1/4	17	10
RT-DM-10/03	26,8	18,7	8,5	10	G3/8	20	10
RT-DM-10/04	25,1	18,7	11	10	G1/2	24	10
RT-DM-12/03	29,6	21,7	8,5	12	G3/8	21	10
RT-DM-12/04	30,6	21,7	11	12	G1/2	24	10
RT-DM-14/03	37,5	24,5	8,5	16	G3/8	24	10
RT-DM-16/04	40	24,5	11	16	G1/2	24	10

STRAIGHT FEMALE

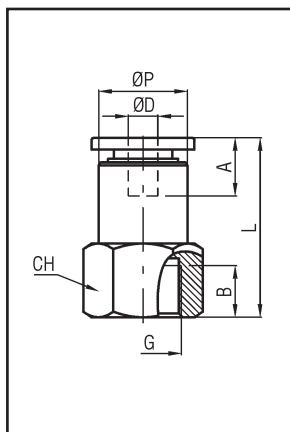

TYPE	L	A	B	ØD	G	ØP	CH	q.ty
RT-DF-4/01	23,5	14,6	7	4	G1/8	10	14	10
RT-DF-6/01	24,4	15,2	7	6	G1/8	12	14	10
RT-DF-6/02	27,4	15,2	10	6	G1/4	12	17	10
RT-DF-8/01	25,1	16,2	7	8	G1/8	14	14	10
RT-DF-8/02	28,1	16,2	10	8	G1/4	14	17	10
RT-DF-8/03	29,1	16,2	11	8	G3/8	14	21	10
RT-DF-10/02	30,5	18,7	10	10	G1/4	17	17	10
RT-DF-10/03	31,5	18,7	11	10	G3/8	17	21	10
RT-DF-12/03	34,6	21,7	11	12	G3/8	20	21	10
RT-DF-12/04	36,6	21,7	13	12	G1/2	20	24	10

SWIVELLING ELBOW MALE

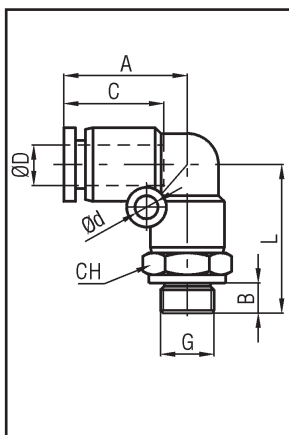

TYPE	L	A	B	C	Ød	ØD	G	CH	q.ty
RT-G-4/M5	18	16	4	13	-	4	M5	8	10
RT-G-6/M5	18	20	4	16	-	6	M5	8	10
RT-G-4/01	24,5	17,7	5,5	15,1	3,2	4	G1/8	14	10
RT-G-4/02	27	17,7	7,5	15,1	3,2	4	G1/4	17	10
RT-G-6/01	25,7	19,3	5,5	16	3,2	6	G1/8	14	10
RT-G-6/02	28,2	19,3	7,5	16	3,2	6	G1/4	17	10
RT-G-8/01	29	22,8	5,5	18,1	3,2	8	G1/8	14	10
RT-G-8/02	31,5	22,8	7,5	18,1	3,2	8	G1/4	17	10
RT-G-8/03	33	22,8	8,5	18,1	3,2	8	G3/8	20	10
RT-G-8/04	37	22,8	11	18,1	3,2	8	G1/2	24	10
RT-G-10/02	35,8	27,6	7,5	20,4	4,2	10	G1/4	17	10
RT-G-10/03	37,3	27,6	8,5	20,4	4,2	10	G3/8	20	10
RT-G-10/04	41,3	27,6	11	20,4	4,2	10	G1/2	24	10
RT-G-12/03	39	29,6	8,5	23,2	4,2	12	G3/8	21	10
RT-G-12/04	45,5	33	11	24,5	5,1	12	G1/2	24	10
RT-G-16/04	45,5	33	11	24,6	5,1	17	G1/2	24	10

SWIVELLING LONG ELBOW MALE

5

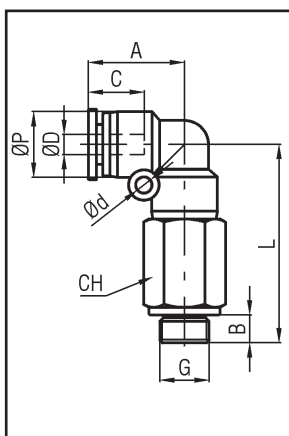

TYPE	L	A	B	C	Ød	ØD	G	ØP	CH	q.ty
RT-GL-4/M5	35	18	4	17	-	4	M5	11	10	10
RT-GL-6/M5	37	20	4	19	6	6	M5	13	12	10
RT-GL-4/01	35,5	17,7	5,5	15,1	3,2	4	G1/8	11	14	10
RT-GL-4/02	39	17,7	7,5	15,1	3,2	4	G1/4	11	17	10
RT-GL-6/01	39,2	19,3	5,5	16	3,2	6	G1/8	13	14	10
RT-GL-6/02	42,2	19,3	7,5	16	3,2	6	G1/4	13	17	10
RT-GL-6/03	43,7	19,3	8,5	16	3,2	6	G3/8	13	20	10
RT-GL-8/01	44,3	22,8	5,5	18,1	3,2	8	G1/8	14,8	14	10
RT-GL-8/02	46,8	22,8	7,5	18,1	3,2	8	G1/4	14,8	17	10
RT-GL-8/03	48,4	22,8	8,5	18,1	3,2	8	G3/8	14,8	20	10
RT-GL-10/02	56,3	27,6	7,5	20,4	4,2	10	G1/4	18,4	17	10
RT-GL-10/03	57,3	27,6	8,5	20,4	4,2	10	G3/8	18,4	20	10
RT-GL-10/04	60,8	27,6	11	20,4	4,2	10	G1/2	18,4	24	10
RT-GL-12/03	62,5	29,6	8,5	23,2	4,2	12	G3/8	21	21	10
RT-GL-12/04	65,5	29,6	11	23,2	4,2	12	G1/2	21	24	10

SWIVELLING CENTRAL TEE

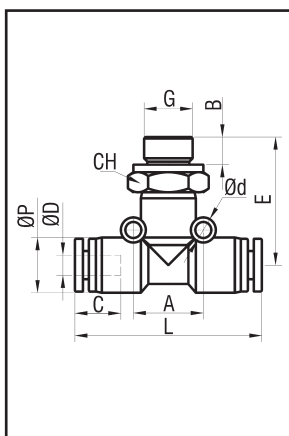

TYPE	L	A	B	C	Ød	ØD	E	G	ØP	CH	q.ty
RT-TC-4/M5	37	15	4	15	5	4	23,5	M5	11	10	10
RT-TC-6/M5	39	16	4	16	6	6	24,5	M5	13	12	10
RT-TC-4/01	37,4	14	5,5	15,1	3,2	4	25,5	G1/8	11	14	10
RT-TC-6/01	39,2	16	5,5	16	3,2	6	26	G1/8	13	14	10
RT-TC-6/02	39,2	16	7,5	16	3,2	6	28,5	G1/4	13	17	10
RT-TC-8/01	45,5	18	5,5	18,1	3,2	8	29	G1/8	14,8	14	10
RT-TC-8/02	45,5	18	7,5	18,1	3,2	8	31,5	G1/4	14,8	17	10
RT-TC-8/03	45,5	18	8,5	18,1	3,2	8	33	G3/8	14,8	20	10
RT-TC-10/02	56,3	24	7,5	20,4	4,2	10	36,5	G1/4	18,4	17	10
RT-TC-10/03	56,3	24	8,5	20,4	4,2	10	38	G3/8	18,4	20	10
RT-TC-10/04	56,3	24	11	20,4	4,2	10	42	G1/2	18,4	24	10
RT-TC-12/03	59,2	27	8,5	23,2	4,2	12	39	G3/8	21	21	10
RT-TC-12/04	59,2	27	11	23,2	4,2	12	43	G1/2	21	24	10

SWIVELLING LATERAL TEE

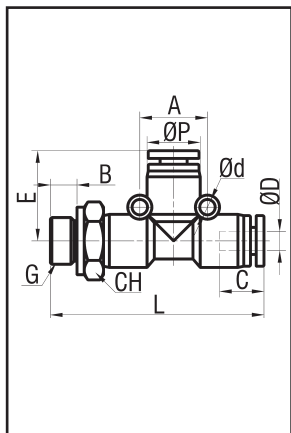

TYPE	L	A	B	C	E	Ød	ØD	G	ØP	CH	q.ty
RT-TL-4/M5	41	14	4	12	18	5	4	M5	11	10	10
RT-TL-6/M5	42,3	16	4	15	18,5	6	6	M5	13	12	10
RT-TL-4/01	44,2	14	5,5	15,1	18,7	3,2	4	G1/8	11	14	10
RT-TL-6/01	45,6	16	5,5	16	19,6	3,2	6	G1/8	13	14	10
RT-TL-6/02	48,1	16	7,5	16	19,6	3,2	6	G1/4	13	17	10
RT-TL-8/01	51,7	18	5,5	18,1	22,8	3,2	8	G1/8	14,8	14	10
RT-TL-8/02	54,2	18	7,5	18,1	22,8	3,2	8	G1/4	14,8	17	10
RT-TL-8/03	55,7	18	8,5	18,1	22,8	3,2	8	G3/8	14,8	20	10
RT-TL-10/02	64,8	24	7,5	20,4	28,3	4,2	10	G1/4	18,4	17	10
RT-TL-10/03	66,3	24	8,5	20,4	28,3	4,2	10	G3/8	18,4	20	10
RT-TL-10/04	70,3	24	11	20,4	28,3	4,2	10	G1/2	18,4	24	10
RT-TL-12/03	68,6	27	8,5	23,2	29,6	4,2	12	G3/8	21	21	10
RT-TL-12/04	72,6	27	11	23,2	29,6	4,2	12	G1/2	21	24	10

SWIVELLING MALE Y

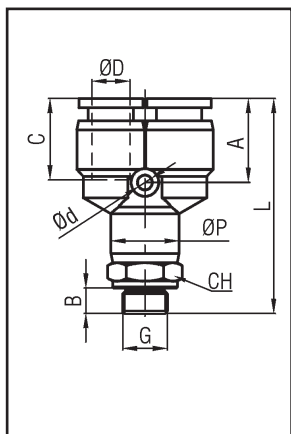

TYPE	L	A	B	C	Ød	ØD	G	ØP	CH	q.ty
RT-YM-4/M5	40	14	4	14	6	4	M5	11	10	10
RT-YM-6/M5	41	14	4	14	6	6	M5	13	12	10
RT-YM-4/01	35,5	10	5,5	15,1	3,2	4	G1/8	11	14	10
RT-YM-6/01	39,2	10,5	5,5	16	3,2	6	G1/8	13	14	10
RT-YM-6/02	42,2	10,5	7,5	16	3,2	6	G1/4	13	17	10
RT-YM-8/01	44,3	13,4	5,5	18,1	3,2	8	G1/8	14,8	14	10
RT-YM-8/02	46,8	13,4	7,5	18,1	3,2	8	G1/4	14,8	17	10
RT-YM-8/03	48,4	13,4	8,5	18,1	3,2	8	G3/8	14,8	20	10
RT-YM-10/02	56,3	15,5	7,5	20,4	4,2	10	G1/4	18,4	17	10
RT-YM-10/03	57,3	15,5	8,5	20,4	4,2	10	G3/8	18,4	20	10
RT-YM-10/04	60,8	15,5	11	20,4	4,2	10	G1/2	18,4	24	10
RT-YM-12/03	62,5	15,5	8,5	23,2	4,2	12	G3/8	21	21	10
RT-YM-12/04	65,5	15,5	11	23,2	4,2	12	G1/2	21	24	10

5

SWIVELLING LOW ELBOW

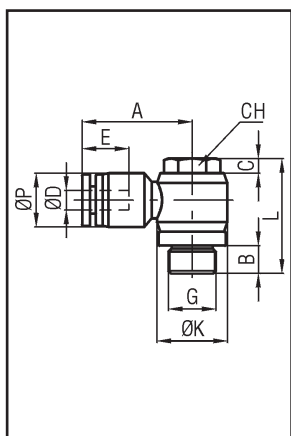

TYPE	L	A	B	C	ØD	E	G	ØK	ØP	CH	q.ty
RT-GG-4/M5	17	22,5	4	3	4	12	M5	10	11	8	10
RT-GG-6/M5	17	23,4	4	3	6	17	M5	10	13	8	10
RT-GG-4/01	23,5	22,5	5,7	3	4	15,1	G1/8	14,4	11	14	10
RT-GG-6/01	23,5	23,4	5,7	3	6	16	G1/8	14,4	13	14	10
RT-GG-6/02	27	25,5	8,3	4	6	16	G1/4	18,3	13	17	10
RT-GG-8/01	23,5	25,6	5,7	3	8	18,1	G1/8	14,4	14,8	14	10
RT-GG-8/02	27	28,7	8,3	4	8	18,1	G1/4	18,3	14,8	17	10
RT-GG-8/03	32,7	29,6	13,9	4,5	8	18,1	G3/8	22	14,8	21	10
RT-GG-10/02	27	33,1	8,3	4	10	20,4	G1/4	18,3	18,4	17	10
RT-GG-10/03	32,7	32,9	13,9	4,5	10	20,4	G3/8	22	18,4	21	10
RT-GG-10/04	38,1	35,9	11	5,5	10	20,4	G1/2	28	18,4	24	10
RT-GG-12/03	32,7	35,6	13,9	4,5	12	23,2	G3/8	22	21	21	10
RT-GG-12/04	38,1	36,6	11	5,5	12	23,2	G1/2	28	21	24	10

SWIVELLING LATERAL MULTI-TEE

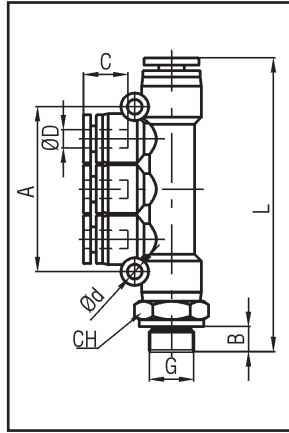

TYPE	L	A	B	C	Ød	ØD	G	CH	q.ty
RT-MTL-4/01	64,2	36	5,5	15,1	3,2	4	G1/8	14	10
RT-MTL-4/02	66,7	36	7,5	15,1	3,2	4	G1/4	17	10
RT-MTL-6/01	68,6	42	5,5	16	3,2	6	G1/8	14	10
RT-MTL-6/02	71,1	42	7,5	16	3,2	6	G1/4	17	10
RT-MTL-6/03	72,6	42	8,5	16	3,2	6	G3/8	20	10
RT-MTL-8/01	87,8	48	5,5	18,1	3,2	8	G1/8	14	10
RT-MTL-8/02	90,3	48	7,5	18,1	3,2	8	G1/4	17	10
RT-MTL-8/03	91,8	48	8,5	18,1	3,2	8	G3/8	20	10

SWIVELLING DIFFERENT Ø LATERAL MULTI-TEE

5

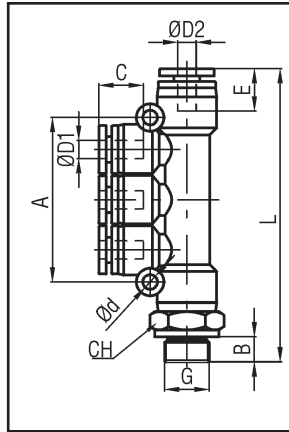

TYPE	L	A	B	C	Ød	ØD1	ØD2	E	G	CH	q.ty
RT-MDL6/4/01	64,2	36	5,5	16	3,2	4	6	15,1	G1/8	14	10
RT-MDL8/4/02	70,7	42	7,5	18,1	3,2	4	8	15,1	G1/4	17	10
RT-MDL8/6/02	71,1	42	7,5	18,1	3,2	6	8	16	G1/4	17	10
RT-MDL10/8/03	91,8	48	8,5	20,4	3,2	8	10	18,1	G3/8	20	10

UNION STRAIGHT

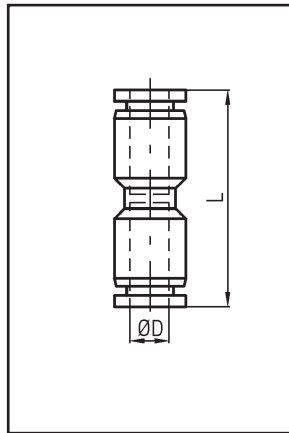

TYPE	L	ØD	q.ty
RT-DI-4	33	4	10
RT-DI-6	35,2	6	10
RT-DI-8	39,1	8	10
RT-DI-10	47,8	10	10
RT-DI-12	49,2	12	10
RT-DI-16	51	16	10

REDUCED UNION STRAIGHT

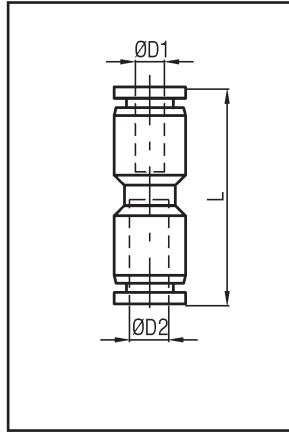

TYPE	L	ØD1	ØD2	q.ty
RT-DIR-6/4	34,9	6	4	10
RT-DIR-8/6	38,6	8	6	10
RT-DIR-10/8	47,3	10	8	10
RT-DIR-12/10	48,9	12	10	10
RT-DIR-16/12	51	16	12	10

UNION ELBOW

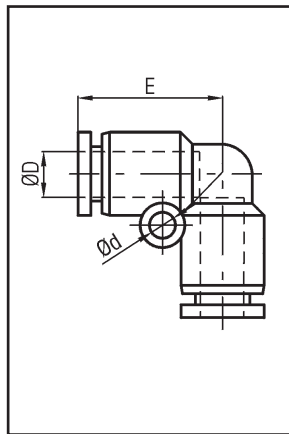

TYPE	ØD	Ød	E	q.ty
RT-GI-4	4	-	17,5	10
RT-GI-6	6	3,2	19	10
RT-GI-8	8	3,2	22,8	10
RT-GI-10	10	4,2	27,6	10
RT-GI-12	12	4,3	29,6	10
RT-GI-16	16	5,1	33	10

5

UNION TEE

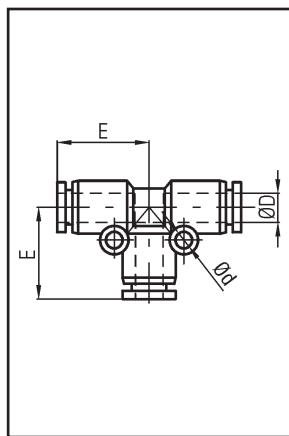

TYPE	ØD	Ød	E	q.ty
RT-TI-4	4	3,2	18,5	10
RT-TI-6	6	3,2	19,3	10
RT-TI-8	8	3,2	22,75	10
RT-TI-10	10	4,2	28,3	10
RT-TI-12	12	4,3	29,6	10

UNION Y

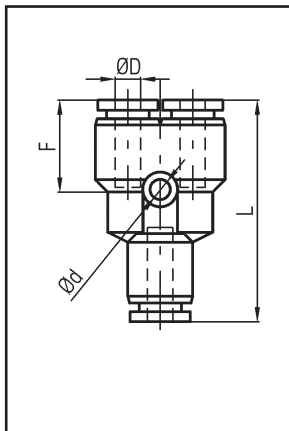

TYPE	L	Ød	ØD	F	q.ty
RT-YI-4	35,5	3,2	4	14	10
RT-YI-6	37,1	3,2	6	14,8	10
RT-YI-8	40,4	3,2	8	18,2	10
RT-YI-10	49,7	4,2	10	20,8	10
RT-YI-12	53,2	4,2	12	21,6	10

REDUCED UNION Y

5

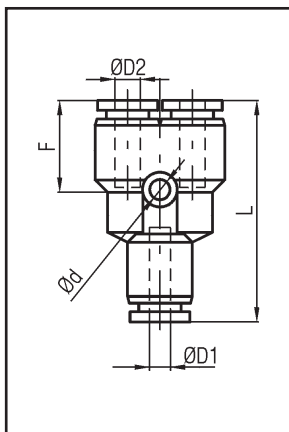

TYPE	L	Ød	ØD1	ØD2	F	q.ty
RT-YIR-6/4	36,8	3,2	6	4	14,5	10
RT-YIR-8/6	39,9	3,2	8	6	17,7	10
RT-YIR-10/8	49,2	4,2	10	8	20,3	10
RT-YIR-12/10	52,9	4,2	12	10	21,3	10
RT-YIR-16/12	62	5,1	16	12	24,5	10

CROSS JUNCTION

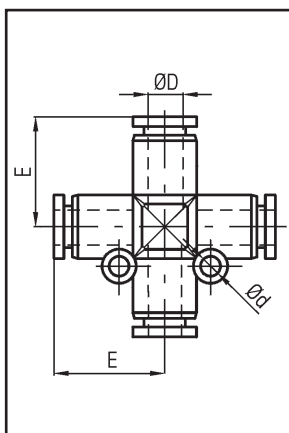

TYPE	ØD	Ød	E	q.ty
RT-C-4	4	3,2	17,5	10
RT-C-6	6	3,2	19,3	10
RT-C-8	8	3,2	22,75	10
RT-C-10	10	4,2	28,3	10
RT-C-12	12	4,3	29,6	10

MULTI-TEE

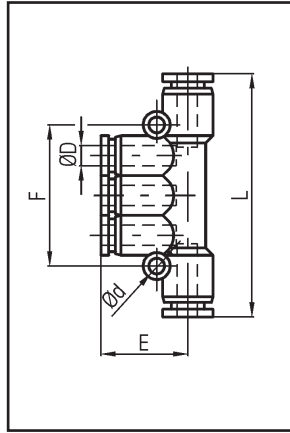

TYPE	L	Ød	ØD1	E	F	q.ty
RT-MT-4	57	3,2	4	19	36	10
RT-MT-6	61	3,2	6	20,3	42	10
RT-MT-8	81,6	3,2	8	24,3	48	10

DIFFERENT Ø MULTI-TEE

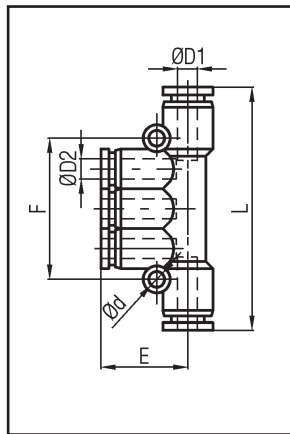

TYPE	L	Ød	ØD1	ØD2	E	F	q.ty
RT-MTD-6/4	57,6	3,2	6	4	19	36	10
RT-MTD-8/4	62,6	3,2	8	4	20	42	10
RT-MTD-8/6	62,6	3,2	8	6	20,3	42	10
RT-MTD-10/6	77,3	3,2	10	6	23,8	48	10
RT-MTD-10/8	77,3	3,2	10	8	24,3	48	10

5

REDUCER

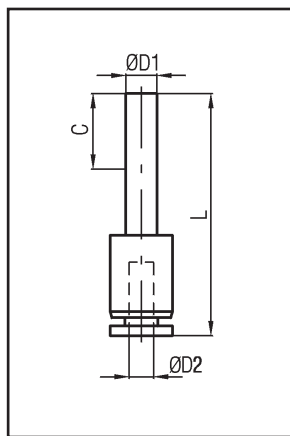

TYPE	L	C	ØD1	ØD2	q.ty
RT-RC-6/4	42	17	6	4	10
RT-RC-8/4	44,5	18	8	8	10
RT-RC-8/6	45	18	8	8	10
RT-RC-10/6	47	20	10	10	10
RT-RC-10/8	47	20	10	10	10
RT-RC-12/8	54	23,5	12	12	10
RT-RC-12/10	54,5	23,5	12	12	10

BULKHEAD CONNECTOR

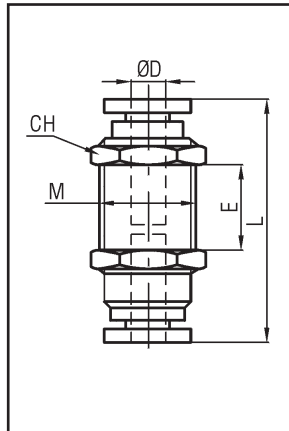

TYPE	L	ØD	E	M	CH	q.ty
RT-P-4	30,1	4	9,7	M12	14	10
RT-P-6	31,8	6	7,5	M14	17	10
RT-P-8	35,3	8	6,8	M16	19	10
RT-P-10	41,6	10	11,5	M20	24	10
RT-P-12	45,3	12	12,8	M22	27	10

MALE PLUG

5

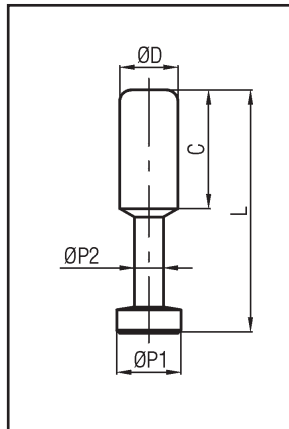

TYPE	L	C	ØD	ØP1	ØP2	q.ty
RT-TM-4	28	15	4	5	3	10
RT-TM-6	33	17	6	7	3	10
RT-TM-8	37	18	8	9	4	10
RT-TM-10	42	20,5	10	11	5	10
RT-TM-12	44	23	12	13	6	10

SWIVELLING MALE/FEMALE ELBOW

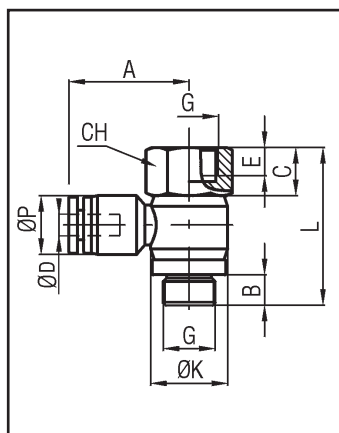

TYPE	L	A	B	C	ØD	E	G	ØK	ØP	CH	q.ty
RT-GMF-4/01	29,5	22,5	5,7	9	4	7	G1/8	14,4	11	14	10
RT-GMF-4/02	35	23,6	8,3	12	4	10	G1/4	18,3	11	17	10
RT-GMF-6/01	29,5	23,4	5,7	9	6	7	G1/8	14,4	13	14	10
RT-GMF-6/02	35	25,5	8,3	12	6	10	G1/4	18,3	11	17	10
RT-GMF-8/01	29,5	25,6	5,7	9	8	7	G1/8	14,4	14,8	14	10
RT-GMF-8/02	35	28,7	8,3	12	8	10	G1/4	18,3	14,8	17	10
RT-GMF-8/03	41,2	29,6	13,9	13	8	11	G3/8	22	14,8	21	10
RT-GMF-8/04	47	32,6	11	14,4	8	13	G1/2	28	14,8	24	10
RT-GMF-10/02	35	33,1	8,3	12	10	10	G1/4	18,3	18,4	17	10
RT-GMF-10/03	41,2	32,9	13,9	13	10	11	G3/8	22	18,4	21	10
RT-GMF-10/04	47	35,9	11	14,4	10	13	G1/2	28	18,4	24	10
RT-GMF-12/02	35	33,5	8,3	12	12	10	G1/4	18,3	21	21	10
RT-GMF-12/03	41,2	35,6	13,9	13	12	11	G3/8	22	21	21	10
RT-GMF-12/04	47	36,6	11	14,4	12	13	G1/2	28	21	24	10

INLINE UNIDIRECTIONAL FLOW REGULATOR

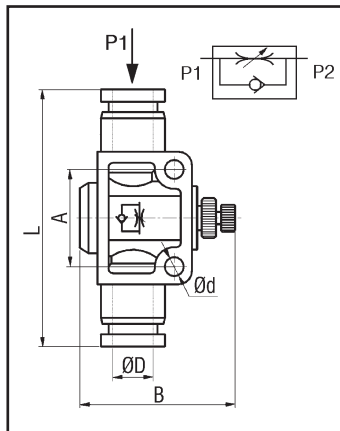

TYPE	L	A	B	Ød	ØD	q.ty
RT-RFL-4	39,5	14	25,7	3,2	4	10
RT-RFL-6	47,6	20	41,9	4,3	6	10
RT-RFL-8	52,6	22	45,6	4,3	8	10
RT-RFL-10	63,1	26	52,3	4,3	10	10
RT-RFL-12	74,2	32	55	4,3	12	10

UNIDIRECTIONAL FLOW REGULATOR FOR CYLINDER (OUT)

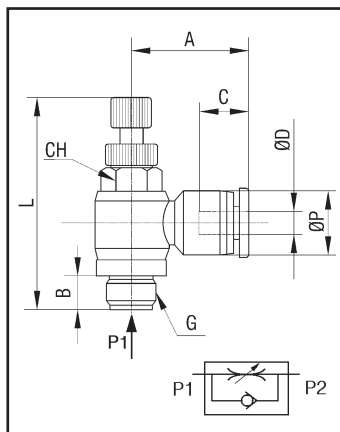

TYPE	L	A	B	C	ØD	G	ØP	CH	q.ty
RT-RF-4/M5	28,2	21	5	12	4	M5	11	8	10
RT-RF-6/M5	28,2	21	-	-	6	M5	13	8	10
RT-RF-4/01	41,1	22,5	5,7	15,1	4	G1/8	10	10	10
RT-RF-4/02	48,8	24,3	8,3	15,1	4	G1/4	10	14	10
RT-RF-6/01	41,1	23,4	5,7	16	6	G1/8	12	10	10
RT-RF-6/02	48,8	25,5	8,3	16	6	G1/4	12	14	10
RT-RF-8/01	41,1	25,6	5,7	18,1	8	G1/8	14	10	10
RT-RF-8/02	48,8	28,7	8,3	18,1	8	G1/4	14	14	10
RT-RF-8/03	54,5	29,6	13,9	18,1	8	G3/8	14	19	10
RT-RF-10/02	48,8	32,3	8,3	20,4	10	G1/4	17	14	10
RT-RF-10/03	54,5	32,9	13,9	20,4	10	G3/8	17	19	10
RT-RF-10/04	60	35,9	11	20,4	10	G1/2	17	19	10
RT-RF-12/03	54,5	35,6	13,9	23,2	12	G3/8	20	19	10
RT-RF-12/04	60	36,6	11	23,2	12	G1/2	20	24	10

5

UNIDIRECTIONAL FLOW REGULATOR FOR VALVE (IN)

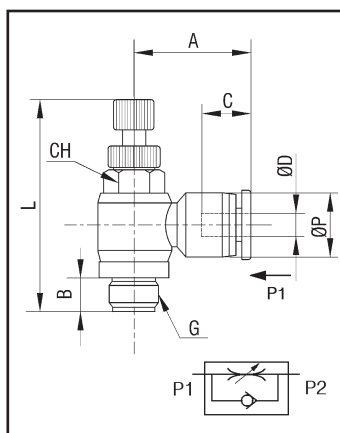

TYPE	L	A	B	C	ØD	G	ØP	CH	q.ty
RT-RFV-4/M5	28,2	21	5	12	4	M5	10	8	10
RT-RFV-6/M5	28,2	21	5	16	6	M5	13	8	10
RT-RFV-4/01	41,1	22,5	5,7	15,1	4	G1/8	10	10	10
RT-RFV-4/02	48,8	24,3	8,3	15,1	4	G1/4	10	14	10
RT-RFV-6/01	41,1	23,4	5,7	16	6	G1/8	12	10	10
RT-RFV-6/02	48,8	25,5	8,3	16	6	G1/4	12	14	10
RT-RFV-8/01	41,1	25,6	5,7	18,1	8	G1/8	14	10	10
RT-RFV-8/02	48,8	28,7	8,3	18,1	8	G1/4	14	14	10
RT-RFV-8/03	54,5	29,6	13,9	18,1	8	G3/8	14	19	10
RT-RFV-10/02	48,8	32,3	8,3	20,4	10	G1/4	17	14	10
RT-RFV-10/03	54,5	32,9	13,9	20,4	10	G3/8	17	19	10
RT-RFV-10/04	60	35,9	11	20,4	10	G1/2	17	19	10
RT-RFV-12/03	54,5	35,6	13,9	23,2	12	G3/8	20	19	10
RT-RFV-12/04	60	36,6	11	23,2	12	G1/2	20	24	10