

DESCRIPTION

Valves series "VM" generate vacuum using the Venturi effect. These valves found a specific employment in the aspiration from single work points with a suction cap.



2

TECHNICAL DATA

Operating pressure	1 ÷ 10 bar
Fluid	Vacuum
Feeding fluid	Compressed air
Port size	G 1/8 - G 1/4 - G 3/8 - G 1/2 - G 3/4 - G 1
Nominal diameter	1,5 mm
Max. vacuum capability	- 0.7 bar

MATERIALS

Body	Anodized aluminium alloy
Nozzle	Brass
Seals	NBR rubber

SUCTION CHART

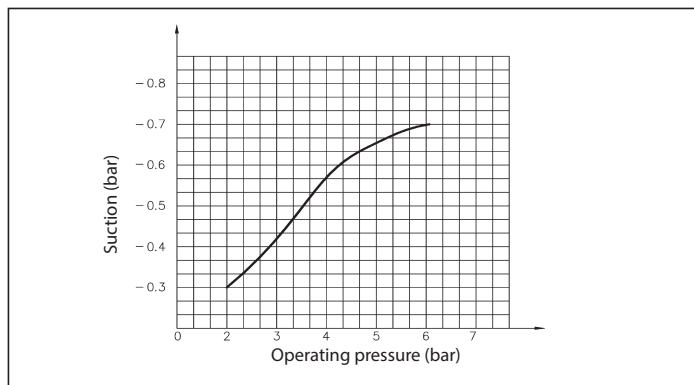

DIMENSIONS AND WEIGHT VM

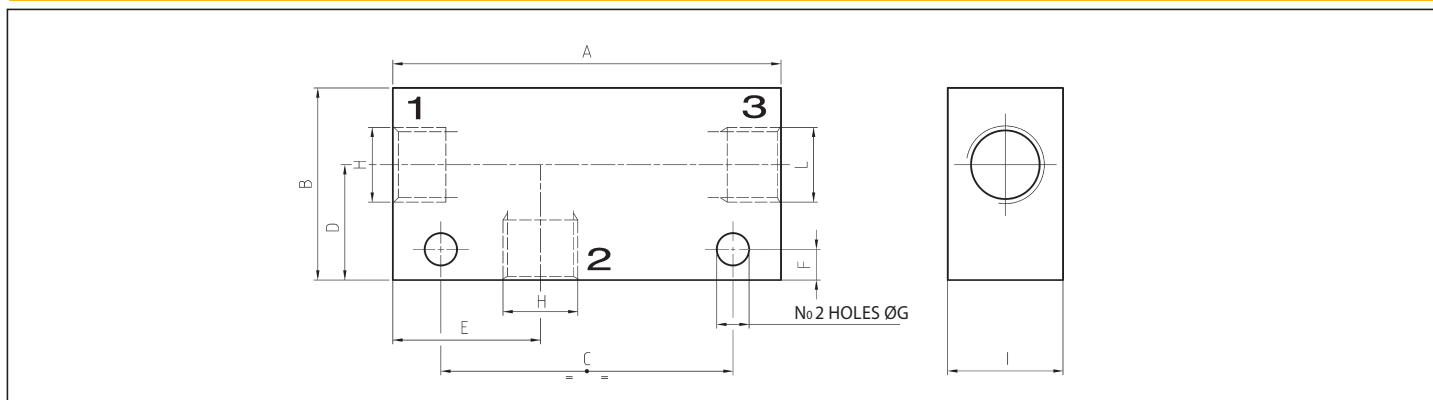

1 = FEEDING FLUID
2 = SUCTION
3 = EXHAUST

Symbol	A	B	C	D	E	F	G	I	H	L	WEIGHT (g)	TYPE
	50.5	25	38	15	19.2	4	4.2	15	G 1/8	G 1/8	50	VM8
	58	30	38	19.5	23	4	4.2	25	G 1/4	G 1/4	90	VM4
	71.5	30	52	18.5	31	4.5	5.2	25	G 3/8	G 3/8	146	VM3
	75	35	56	21	33	4.5	5.2	30	G 1/2	G 1/2	203	VM2
	90.5	50	61.5	28.5	49.4	4.5	5.2	50	G 3/4	G 1/4	692	VM15
	97	50	68	28.5	52.4	4.5	5.2	50	G 1	G 1/4	643	VM1

SUCTION FLOW RATE

